



Auto System Installation/Owner's Manual



***QUADRA* Mfg.Inc.**

CORPORATE

305 US 131 SOUTH
P.O. BOX 536
WHITE PIGEON, MI 49099
269 483-9634
269 483-9636 FAX

SOUTHERN DIVISION

4411 Holden Rd
Lakeland, FL 33811
863 619-8617

PREPARATION FOR INSTALLATION

BEFORE BEGINNING THE INSTALLATION, CHECK THE CONTENTS OF ALL BOXES RECEIVED AGAINST THE FOLLOWING PARTS/ITEMS LIST. PLEASE CALL QUADRA IMMEDIATELY IF THERE IS A DISCREPANCY.

BASIC PARTS/ITEMS LIST FOR A LEVELING SYSTEM

- **CYLINDERS:** Four cylinders made-up of various sizes and models based on vehicle: make, model and measurements provided to Quadra Mfg. at the time of ordering.
- **ONE CONTROL PANEL:** Panel, pigtail, bezel and gasket with six #4 black screws (sensor with interface harness, four #8 bolts and locknuts if applicable to model)
- **ONE CONTROL HARNESS:** Model 200 for QE-I or model 300 for QE-II
- **TANK COVERS:** One per tank assembly
- **COMPLETE TANK ASSEMBLY:** One per cylinder. Each tank assembly is composed of one tank body and reservoir, on pump motor, one copper strip and two solenoids.
- **HYDRAULIC LINE:** High pressure flexible lines with 37° female ends (2 per cylinder).
- **LIMIT SWITCHES:** One per cylinder
- **CABLE TIES:** Thirty per system
- **BRACKETS:** One per cylinder
- **8" x 8" FLAT PLATES:** Optional item for remote mounts at additional cost.
- **FOOT PADS:** One per cylinder
- **CLEVIS PINS:** One per cylinder
- **FOOT NUTS:** One per cylinder
- **7/16 X 1 ¾ long GRADE 8 SHANK BOLTS:** Four per QE-I cylinder (six for QE-II)
- **7/16 X 1 ½ long GRADE 8 FULL THREADED BOLTS:** Eight per system (if 8"x8" PLATES are ordered)
- **7/16 GRADE 8 HEX NUTS AND LOCK WASHERS:** Equal to number of bolts
- **#10 x ¾ TEK SCREW:** One per tank cover
- **90° FITTINGS:** Two per cylinder
- **BATTERY LUGS:** Two per system
- **120 AMP BREAKER:** One per system, auto reset
- **#10 x 1 ¼ TEK BREAKER SCREW:** Two per system

THE FOLLOWING INSTRUCTIONS WILL PROVIDE YOU WITH ALL OF THE BASIC INFORMATION YOU WILL NEED TO SUCCESSFULLY COMPLETE THE INSTALLATION. PLEASE BE AWARE THAT EVERY INSTALLATION MAY VARY DUE TO THE WIDE VARIETY OF VEHICLE CONFIGURATIONS. IF AT ANY TIME DURING THE INSTALLATION YOU HAVE A QUESTION PLEASE CALL 1-269-483-9633 AND ASK FOR A SERVICE TECH.

CYLINDER INSTALLATION

TO START:

- Remove the battery cables from the battery. This is for your safety and the battery should not be reconnected until the installation is completed.

DETERMINE MOUNTING LOCATION:

- Other locations on the frame may be acceptable. Call Quadra to discuss custom installation.
- Class A: Front cylinders should be 2-3 ft behind the front axle, and the rear cylinders as close to the rear axle as possible. It is not recommended that the cylinders are mounted to the frame extension.
- Class C: Front cylinder on frame just behind chassis cutaway OR under the cab, rear cylinders should be 2-3 ft behind rear axle.

INSTALLING THE 90° FITTING:

- Determine if you will be doing a direct or indirect mount. This determines which port in the top of the cylinder to install the 90° fitting in.
- For a direct mount, use the port on the opposite side of the pump unit.
- For a remote mount use the port closest to the pump unit.
- Make sure the "O" ring and washer are on the 90° fitting behind the threads, position the fitting and screw it loosely onto the cylinder. Wait to tighten the jam nut completely, so that the fitting can be turned to a desirable position when installing the hydraulic flex line. At that time, tighten the jam nut while holding the fitting with a second wrench. Drop the clevis pin into the limit switch barrel at the bottom of the cylinder and screw the limit switch into the barrel. The cylinder is not ready to be attached to the vehicle.

MOUNTING THE CYLINDERS

NOTE: DO NOT USE FULL THREADED BOLTS TO MOUNT THE CYLINDERS. THESE BOLTS ARE FOR TANK MOUNTING ONLY.

BEFORE ANY CYLINDERS ARE MOUNTED

- Determine where each cylinder will be located by taking measurements from the top of the frame to the ground and from the floor of the coach to the ground. Different length cylinders may be required in the front and rear of vehicle.

POSITIONING THE CYLINDER:

- Bolt your cylinder to the frame or to the weld on bracket to mount, so that it will have 7-8" of road clearance. Allow ¼" for the footpad. The cylinder height can be adjusted by moving the cylinder up or down on the mounting bolts. The holes are in 1" increments.

TO BOLT ON:

- Mark where the cylinder is going to be positioned on the frame, making sure that the cylinder is level front to rear and side to side, and drill holes in the frame of coach, using caution to make sure your not drilling into any wires, brake or fuel lines.

TO WELD ON:

- Use the weld-on brackets provided with your leveling system.
- Tighten all cylinder mounting bolts with a hand wrench.
- Install nuts by hand or use air tools. Do not torque with a power tool. Final torque should be done with a hand torque wrench. Installed torque will be 70 ft. lbs.
- For QE-I cylinders (2 7/8 Dia.): You must use four 7/16 x 1 ¾ GRADE 8 BOLTS (provided) to mount the cylinders to the frame or weld-on bracket.
- For QE-II cylinders (3 3/8 Dia.): You must use six 7/16 x 1 ¾ GRADE 8 BOLTS (provided) to mount the cylinder to the frame or the weld-on bracket.
- Position the cylinders using a floor jack or blocks set the cylinder in place, making sure that it is plumb, and allowing for the 7-8" of road clearance. Secure the cylinder to the frame with a large C-clamp, or locking plier type clamps. Tack weld both sides and recheck for plumb. Weld, making sure to get good penetration.

TANK INSTALLATION

FILL THE RESERVOIR WITH 60 OUNCES OF DEXRON III TRANSMISSION FLUID BEFORE MOUNTING TANK ASSEMBLY UNDER THE COACH.

DIRECT MOUNT

- Each pump assembly has 6 mounting holes on each side, which allows for height adjustment. The holes are 1" on center.
- You need to leave a minimum of two bolt holes between each mounting bolt that secures the tank assembly. (2 bolts are provided)
- Make sure mounted tank assembly is still above the top of the footpad.

REMOTE MOUNT

- If there is no room for a direct mount of the tank assembly to the cylinder, it can be mounted at a remote location.
- Use the optional 8 ¼" x 8 ¼" plate welded or bolted to the frame or cross member. Suggested locations are inside the frame, inside the wheel well, or in a storage compartment.

NOTE: EXTENSIONS TO WIRING HARNESS MAYBE NECESSARY, AS WELL AS LONGER HYDRAULIC LINES.

CONTROL HARNESS INSTALLATION

IMPORTANT! DO NOT PATCH INTO THE HARNESS FOR POWER OR GROUND PURPOSES. THE CONTROL HARNESS SUPPLIED WITH YOUR BIGFOOT LEVELING SYSTEM IS INTENDED FOR THE LEVELING SYSTEM ONLY. IF YOU PATCH INTO THE HARNESS YOU CAN POTENTIALLY CAUSE FEED BACK TO THE CONTROL PANEL, WHICH MAY DAMAGE IT. ALSO, THE WARRANTY OF THE ENIRE SYSTEM WILL BECOME VOID.

GENERAL INSTALLAION NOTES:

- Keep all wires away from the engine, mufflers, exhaust system and moving parts. Secure all wires with wire ties, especially the heavy duty battery cable assembly where it goes over any drive line parts (ties are provided). Take care in the installation of the power and control cable; keep them free from sharp edges that could cause direct shorts, moveable parts and hot areas.

RUN THE CONTROL HARNESS INTO THE VEHICLE:

- Be sure there are no wires, cables or other objects that could be damaged when drilling the hole for the harness to run through.
- Drill a 1 ¼" hole at the back of the firewall leading into the vehicle as close to the panel location as possible.
- Push plug end of harness into the hole and up to the location of the panel or sensor. Be sure that you do not run the harness around or over the steering arm or brake pedals where it could be damaged or affect the performance of the vehicle.
- Leave an extra six inches of slack in the harness where it plugs into the panel or sensor. This will allow you enough room to remove the panel should it ever be necessary to do so.
- Pull excess wire, leaving the six inches of slack, back through the hole in the firewall and secure the harness outside the coach with the wire ties that are provided with the leveling system.
- Seal the hole in the firewall with silicon or insulating spray foam.
- Run the remainder of the harness from firewall down the left side of the vehicle to the back left side of the vehicle to the left rear tank assembly. The harness can be run inside or outside of the frame. Tie every 24"
- It is suggested that you run the harness with the vehicles existing harness to provide something to secure the harness to.
- Next, run each of the four legs of the harness to their correct tank location. See main wire harness diagram on pg. 15. The legs of the harness are different lengths so there is enough harness to reach each tank assembly.

NOTE: BE SURE THE HARNESS AND ALL FOUR LEGS ARE SECURED AND NOT TOUCHING OR RESTING ON ANYTHING THAT IS HOT, SHARP OR MOVING.

POWER CABLE INSTALLATION

WARNING: THE POWER CABLE SHOULD NOT BE HOOKED TO THE BATTERY UNTIL THE INSTALLATION IS COMPLETE. THIS IS TO PREVENT THE SYSTEM FROM BEING OPERATED WHILE SOMEONE IS UNDER THE VEHICLE DOING THE INSTALLATION.

NOTE: DO NOT TIE TO ANYTHING THAT MOVES. (FOR EXAMPLE: SHOCK ABSORBERS, SLIDE MECHANISMS, ETC.)

NOTE: WHEN RUNNING THE LONGER LEGS OF THE POWER CABLE ACROSS THE VEHICLE TO THE TANK ASSEMBLIES ON THE PASSENGER SIDE, BE SURE THAT YOU KEEP THEM CLEAR OF SHARP, MOVING AND/OR HOT SURFACES.

- Route the power cable next to the control harness on the driver's side of the vehicle.
- Each leg of the harness goes to the tank assembly, the short legs to the driver's side and the longer legs to the passenger's side. Use the longest to reach the coach (house) battery(s).
- The power cable may be run in either direction, depending on where the coach (house) battery(s) are located. There should be excess amount of power cable located at the spot of the coach (house) battery(s) to hook up the system breaker.
- The breaker should be located in the coach (house) battery compartment. Find a place to locate the breaker and screw it down with the #10 x 1 ¼" tech screws (provided). Do not over tighten. Give yourself 6" of slack, cut off the excess battery cable, and set it aside.
- Strip back 6" of wire loom to expose the red cable.
- Next strip ½" of red jacketing off of the wire and install a battery lug (provided) on the end.
- Hook the power cable to the auxiliary side of the breaker.
- Using the excess part of the cable that you set aside, take the end with the battery lug and connect to the battery side of the breaker. Measure to the positive side of the battery, cut off excess, install battery lug and attach to positive side of battery.
- If the system is using more than one 12-volt coach (house) battery, any of them could be used to pick up power to the breaker.
- If the system is using more than one 6-volt coach (house) battery, you will have to use the battery at the end of the series. Check to see if the battery is carrying 12 volts to be sure it is the last battery in the series.

NOTE: THE POWER CABLE MUST BE CONNECTED TO THE POSITIVE (+) SIDE OF THE BATTERY.

WIRING THE TANK ASSEMBLY

(SOLENOID WIRING OR REPLACING A SOLENOID)

- Run the limit switch harness into the tank assembly. You can run it through the side and secure it to the hydraulic lines when they are installed or you can run it through one of the three holes in the back of the tank with the plastic grommet insert.
- Fasten the eyelet of the limit switch harness to the bottom mounting bolt of the bottom solenoid. Use ¼" UNC nut supplied on the tank.
- Run the leg of the control harness into the tank through one of the three holes in the back of the tank with the plastic grommet insert.
- Push the wire with the tracer mark onto the silver post on the top solenoid (see tank assembly image on pg. 22) and the solid color wire onto the silver post of the bottom solenoid (see main wire harness diagram on pg. 15).
- The green wire (limit switch) wire will plug into the spade connector on the control harness for that unit after the main harness has been run to each tank assembly.
- Plug the green wire with the spade connector into the main wire harness.
- Run the leg of the power cable into the back of the tank using one of the holes with the plastic grommet insert. Attach the wire to either solenoid using the post with the copper bar (see tank assembly image on pg. 22). Tighten the nut to a maximum of 45" lbs. of torque.

NOTE: TO AVOID PUTTING A HOLE IN THE TANK RESERVOIR WHEN INSTALLING THE PLASTIC COVER, DO NOT GET TOO FAR TO THE RIGHT WITH THE BOTTOM SCREW. FASTEN THE PLASTIC COVER WITH THE TECH SCREWS (PROVIDED). PUT IN THE BOTTOM LEFT/RIGHT CORNER.

HYDRAULIC LINE INSTALLATION

THE SYSTEM IS SHIPPED WITH 24" FLEX LINES WITH 37° J.I.C FEMALE FLARE FITTINGS, UNLESS OTHERWISE SPECIFIED FOR A REMOTE MOUNT.

- Connect the line into the left side fitting on the tank, closest to the reservoir fill cap. Make sure the line is tight. Do not over tighten.
- Run this line to either top port of the cylinder.
- Now tighten the jam nut with the "O" ring if you have not done so already.
- Connect the second line to the retract port which is on the right of the tank assembly, furthest from the fill cap. Run this line to bottom port on the cylinder.
- Now install the 90° fitting into the bottom of the cylinder and install the line onto the fitting.

FOOTPAD INSTALLATION

NOTE: DO NOT USE WASHERS OR SPACERS OF ANY KIND BETWEEN FOOTPAD AND RAM OR FOOTPAD AND NUT. THE FOOTPAD IS DESIGNED TO FLOAT AND PIVOT FOR UN-EVEN SURFACES. USING WASHERS OR SPACERS MAY CAUSE THREAD DAMAGE.

- Slip footpad up over stud on the bottom of the ram. Install ¾" ny-lock jam nut, making sure not to cross thread, and tighten with impact wrench if available.
- Run leg down a couple of inches before final tightening.

AIR DUMP INSTALLATION

YOU WILL NEED AN AIR DUMP FOR EACH BAG THAT HAS A LEVELING VALVE.

NOTE: AIR DUMPS SHOULD BE USED ON ALL AIR-RIDE FRAMES WITHOUT FACTORY DUMPS.

INSTALLING THE AIR DUMP VALVE

- The valve needs one blue or orange wire from the control wire harness and one ground wire.
- Use thread sealer on thread and fitting. Do not get any sealer on the valve.
- Keep valve vertical and be sure to keep the 90° plastic fitting facing down and to the rear.

PREPARING THE AIR DUMP ASSEMBLY

- Wrap the threads of the in-line tee with Teflon tape and screw it into the “in” port on the air dump valve.
- Next, screw the plastic elbow into the “out” port on the air dump valve. No Teflon tape is needed on the plastic elbow.

INSTALLING THE AIR DUMP

- Cut the air-line and install the in-line tee and air dump on the air-line that fills the airbag. This air-line comes from the leveling valve and goes to the top of the airbag.
- Ground one of the two black wires to the frame of the coach and using the proper connector, connect the other wire to the blue or orange air dump wire in the main wire harness.
- Repeat this step for each of the air bags that have a leveling valve.

MANUAL PANEL INSTALLATION

WARNING: FOR MOUNTING THE PANEL, USE THE #4 SCREWS PROVIDED ONLY. NEVER DRILL OVERSIZED HOLES IN THE CIRCUIT BOARD, USE ONLY A 7/64" DRILL BIT TO GO THROUGH THE MYLAR OVER THE PRE-EXISTING HOLES IN THE CIRCUIT BOARD.

YOU MUST USE THE FOAM GASKET ON THE BACK OF THE CIRCUIT BOARD IF MOUNTING ON A METAL SURFACE. WE RECOMMEND USING THE FOAM GASKET IN ALL INSTALLATIONS.

ESTABLISHING PANEL LOCATION

- Cut a hole into the dash where the panel will be located. This hole should allow you enough room to adjust the panel and set it straight in the hole. If the panel is being flush mounted in the vehicle dash, be sure that there are not wires, heating or air-conditioning ducts, cables...etc., behind the dash where they could be cut or damaged when cutting the hole for the panel.

DO NOT SCREW THE PANEL DOWN UNTIL THE POWER PIGTAIL AND THE HARNESS ARE PLUGGED INTO THE PANEL.

CONNECT POWER PIGTAIL

- Plug the 6-pin connector of the pigtail into the mating connector on the back of the panel.
- Ground the black wire to the vehicle. Be sure this wire has a ground that is separate from all other grounded wires.
- Using proper wire connectors, connect the red wire of the pigtail to a constant hot source (battery positive).
- Connect the yellow wire of the pigtail to the accessories (ACC) side of the ignition switch, or ACC tap at the fuse block.
- The blue wire of the pigtail is to be grounded, separate from all other grounded wires. The park brake LED on the panel serves only to remind operator to set the park brake before leveling.
- The orange wire of the pigtail is only for systems using air dumps provided by Quadra Mfg. Inc. If the system you are installing does not use these air dumps the orange wire must be taped and/or capped off to prevent a short. If the system you are installing does use air dumps provided by Quadra Mfg. Inc., using the appropriate wire connector, connect the orange wire from the power pigtail to the blue wire that is loose at the 14-pin connector of the control harness.

MANUAL 6-PIN PIGTAIL

#M43500

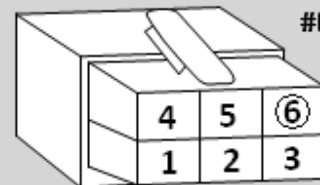

1. YELLOW - IGNITION ACC
2. ORANGE - AIR DUMP
3. BLUE - PARK BRAKE
4. BLACK - GROUND
5. RED - CONSTANT HOT
6. OPEN

CONNECT MAIN HARNESS

- Plug the 14-pin connector of the main harness into the mating connector on the back of the control panel.

INSTALLATION OF PANEL

- Apply foam gasket to the back of the panel.
- Place panel into previously cut hole.
- Apply mounting bezel to front of the panel.
- Using the six #4 screws provided, screw panel into place.

AUTO PANEL INSTALLATION

PANEL WIRING – FOUR-WIRE PIGTAIL

AUTO CONTROL PANELS WITH SENSOR WILL UTILIZE A 6-PIN CONNECTOR WITH ONLY 4 WIRES.

- Ground the black wire to the vehicle. Be sure this wire has ground that is separate from all other grounded wires.
- Using the proper wire connectors, connect the red or white wire of the pigtail to the constant hot wire and connect the yellow wire of the pigtail to the accessories (ACC) side of the ignition switch, or ACC. Tap at the fuse block.
- If the system you are installing does use air dumps provided by Quadra Mfg. Inc., using the appropriate wire connector, connect the orange wire from the power pigtail to the orange wire that is loose at the 14-pin connector of the control harness. If the system you are installing does not use these air dumps the orange wire must be taped and/or capped off to prevent a short.

STANDARD 6-PIN PIGTAIL

#M43550

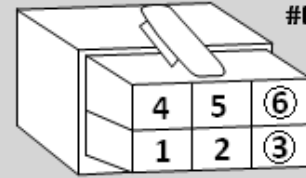

1. YELLOW - IGNITION SWITCH
2. ORANGE - AIR DUMP
3. OPEN
4. BLACK - GROUND
5. RED - BATTERY
6. OPEN

MOUNTING THE PANEL

WARNING: FOR MOUNTING THE PANEL, ONLY USE THE #4 SCREWS PROVIDED. NEVER DRILL OVERSIZED HOLES IN THE CIRCUIT BOARD. YOU MUST USE THE FOAM GASKET ON THE BACK OF THE CIRCUIT BOARD IF MOUNTING ON A METAL SURFACE. WE RECOMMEND USING THE FOAM GASKET IN ALL INSTALLATIONS. (SEE MANUAL PANEL INSTALLATION ON PG. 8)

BEZEL MOUNTING RING

- Use the bezel mounting ring (supplied) whenever possible. This will eliminate the need to drill out the mylar cover on the Automatic and Semiautomatic Control Panels.
- However, if you need to drill this out, use a 7/64" drill bit NO LARGER.

FLUSH MOUNTING PANEL IN THE VEHICLE DASH:

- Do not screw the panel down until the harness is plugged into the panel.
- Be sure that there are no wires, heating or air-conditioning ducts, cables...etc., behind the dash where they could be cut or damaged when cutting the hole for the panel.
- Cut the proper hole size into the dash, use the panel template found in the back of this manual on pg. 25, where the panel will be located. | This hole should allow you enough room to adjust the panel and set it straight in the hole.

IMPORTANT: PREPARING THE SENSOR

IT IS VERY IMPORTANT THAT THE SENSOR BE STORED IN A HORIZONTAL POSITION WITH THE STICKER SIDE FACING UP FOR 24 HOURS BEFORE PROGRAMMING (SEE PG. 23).

- If the sensor has been turned 90° (or more) within 24 hours prior to programming, it may need to be re-programmed to achieve optimum leveling. Also, if the sensor is not mounted level with the vehicle it will lessen the range of ability to level.

SENSOR MOUNTING

IMPORTANT: THE SENSOR MUST BE MOUNTED HORIZONTALLY WITH THE STICKER SIDE FACING UP AND THE ARROW POINTING TOWARD THE FRONT OF THE VEHICLE. SENSOR AND BRACKET MUST BE LEVEL.

- Now that the unit has been wired and the vehicle has been leveled, proceed to find a mounting location for the sensor and bracket, inside the coach, away from dampness.
- The sensor bracket can be mounted either on the firewall or either sidewall as long as it is solid metal or wood. Mount the sensor bracket with appropriate screws (not supplied).
- Mount the bracket so that it is level from side to side.
- Once that is done, the bracket must be leveled from front to rear, this can be done by slightly bending the bracket up or down.
- Mount the sensor to the bracket using 4 #8-32 X ¾ long machine screws, lock washers and nuts (provided).

CONNECT THE WIRING

- The leveling system's main harness connects to the rear of the sensor.
- The 6-pin power harness connects to the rear of the sensor.
- Interface harnesses and the 8-pin connectors of the larger harness go into the front of the sensor or control panel.

FULLY-AUTOMATIC CONTROL PANEL WITH SENSOR

STEP 1: TURN THE SYSTEM POWER ON

- On initial start-up, turn the panel on and leave it on for five minutes. The panel will go through a *self-diagnostic mode*. The LED's of the level indicator will cycle and the center logo will flash. This process will last for 30 seconds during which time you will not be able to operate the panel. The panel will then enter *zero mode* and all LED's except the "all up" LED will be flashing.

THE PANEL WILL ENTER A SELF-DIAGNOSTIC MODE EVERY TIME THE POWER IS TURNED ON REGARDLESS OF WHAT MODE THE PANEL IS IN. IT WILL LAST 30 SECONDS.

ZERO MODE: THE CONTROL PANELS ARE SHIPPED IN WHAT IS REFERRED TO AS ZERO MODE. THIS ALLOWS THE INSTALLER TO PROGRAM THE SENSOR AT THE DESIRED LEVEL REFERENCE.

BLEEDING AIR FROM LINES

UPON COMPLETION OF SYSTEM INSTALLATION, BUT BEFORE PROGRAMMING THE SENSOR, THE AIR MUST BE PURGED OUT OF THE LINES AND CYLINDERS FOR PROPER OPERATION OF THE SYSTEM.

- Raise the vehicle off of the ground far enough to fully extend the cylinders without touching the ground (use a hydraulic hoist or drive onto ramps).
- Fully extend each cylinder until you hear the pump motor strain. Achieve full extension without feet touching the ground. **(LEAVE FULLY EXTENDED FOR 15 MINUTES)**
- Fully retract cylinders and check fluid level, using the manual retractor feature. If necessary, fill reservoir to measure $\frac{3}{4}$ " from the top.
- Repeat process as necessary.

STEP 2: PLACE TEMPORARY LEVELS

- Place two temporary levels in the vehicle. (Suggested location for placement of levels is on the kitchen counter next to the stove or in the bottom of the refrigerator.) One should be placed to indicate "level" front to rear and the other to indicate "level" from side to side.

STEP 3: ESTABLISH GROUND CONTACT

- Extend each leveler individually until they touch the ground. You are still in zero mode. This is the only time the panel will allow you to extend the levelers individually.
- The four touch pads of the level indicator will serve to operate each leveler individually. Consult the following diagram to determine which touch pad controls which leveler.

FRONT – RIGHT FRONT LEVELER

LEFT – LEFT FRONT LEVELER

RIGHT – RIGHT REAR LEVELER

REAR – LEFT REAR LEVELER

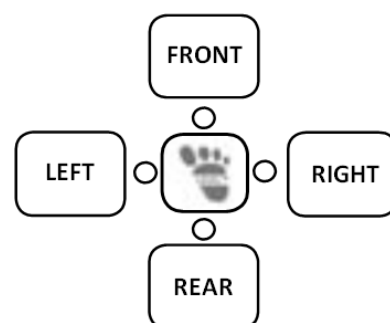

STEP 4: LEVEL THE UNIT

- After you have established ground contact with each individual leveler, operate the levelers in pairs by pressing two touch pads at a time to level the unit. Repeat as necessary until temporary reference levels read level in both front to rear and right to left. Consult the following diagram to determine which touch pads will control which pairs.

FRONT & LEFT – FRONT PAIR

FRONT & RIGHT – RIGHT SIDE PAIR

REAR & RIGHT – REAR PAIR

REAR & LEFT – LEFT SIDE PAIR

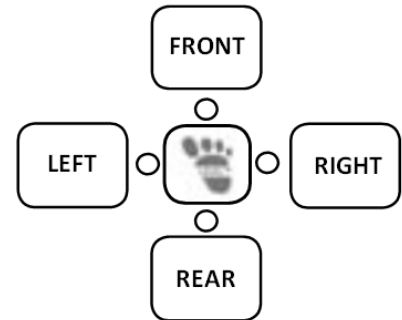

NOTE: READ STEP 6 BEFORE READING STEP 5.

STEP 5: PROGRAM SENSOR

- Wait 30 seconds after getting the unit level and then press the RETRACT touch pad on the control panel three times. The unit is now programmed with its level reference.

STEP 6: AIR DUMP OPTION

- After the RETRACT touch pad has been pressed three times and the unit is programmed with its level point the air dump LED will begin to flash. It will flash for twenty seconds.
- If the unit has air dumps you must press the retract touch pad an additional three times to program that option before the LED has stopped flashing.
- If the unit does not have air dumps then wait twenty seconds for the LED to stop flashing, also at this time the green level light should be flashing.

STEP 7: PRESS THE RETRACT TOUCH PAD

- In automatic mode you only need to push the touch pad once to retract.
- Proceed to the operating instructions.

RE-PROGRAMMING THE PANEL AND SENSOR

- To return to zero mode.... Turn panel off, wait 5 seconds.
- Turn panel on, wait 30 seconds for the self-diagnostics to complete.
- Then press the FRONT touch pad five times and then the REAR touch pad five times (within 10 seconds).
- All the LED lights, except the all up LED, will flash indicating a zero mode.
- Refer to step 3 to finish re-programming sensor.

6 PIN HARNESS

WIRE ENTRY – FRONT VIEW
FULLY AUTOMATIC AND SEMIAUTOMATIC
CONTROL PANEL WITH SENSOR
UTILIZE A 6-PIN CONNECTOR WITH ONLY 4 WIRES.

STANDARD 6-PIN PIGTAIL
#M43550

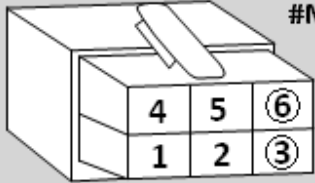

1. YELLOW - IGNITION SWITCH
2. ORANGE - AIR DUMP
3. OPEN
4. BLACK - GROUND
5. RED - BATTERY
6. OPEN

I.D.S. SENSOR

Use with semi and full auto panels. It must be mounted inside the vehicle, out of the elements; preferably driver's seat directly mounted to floor with carpet removed, or on the inside of the firewall or front wall. The arrow must point towards the front of the vehicle when installed. Sensor shown below (on the right) with the AUTO panel.



CONTROL HARNESS

Run control harness and power cable along driver's side of frame rail with the coaches existing harness wire (sometimes on the passenger side, if enclosed, screw to under belly with plastic wire harness clasp). Use care when running wires around axle and exhaust. Protect against sharp edges, secure with cable ties (provided).

CONTROL HARNESS COLOR CODE:

BROWN/WHITE – Right rear top solenoid

BROWN – Right rear bottom solenoid

WHITE/BLACK – Right rear limit switch

BLUE OR ORANGE – Air dump

GRAY/WHITE – Left rear top solenoid

GRAY – Left rear bottom solenoid

WHITE – Left rear limit switch

BLUE OR ORANGE – Air dump

BLUE/WHITE – Right front top solenoid

BLUE – Right front bottom solenoid

PURPLE – Right front limit switch

BLUE OR ORANGE – Air dump

GREEN/WHITE – Left front top solenoid

GREEN – Left front bottom solenoid

TAN – Left front limit switch

BLUE OR ORANGE – Air dump

***NO CONNECTOR ON WIRE FOR AIR DUMP. WIRE ON M300 HARNESS ONLY. NOT ON M200 HARNESS.**

MAIN WIRE HARNESS DIAGRAM

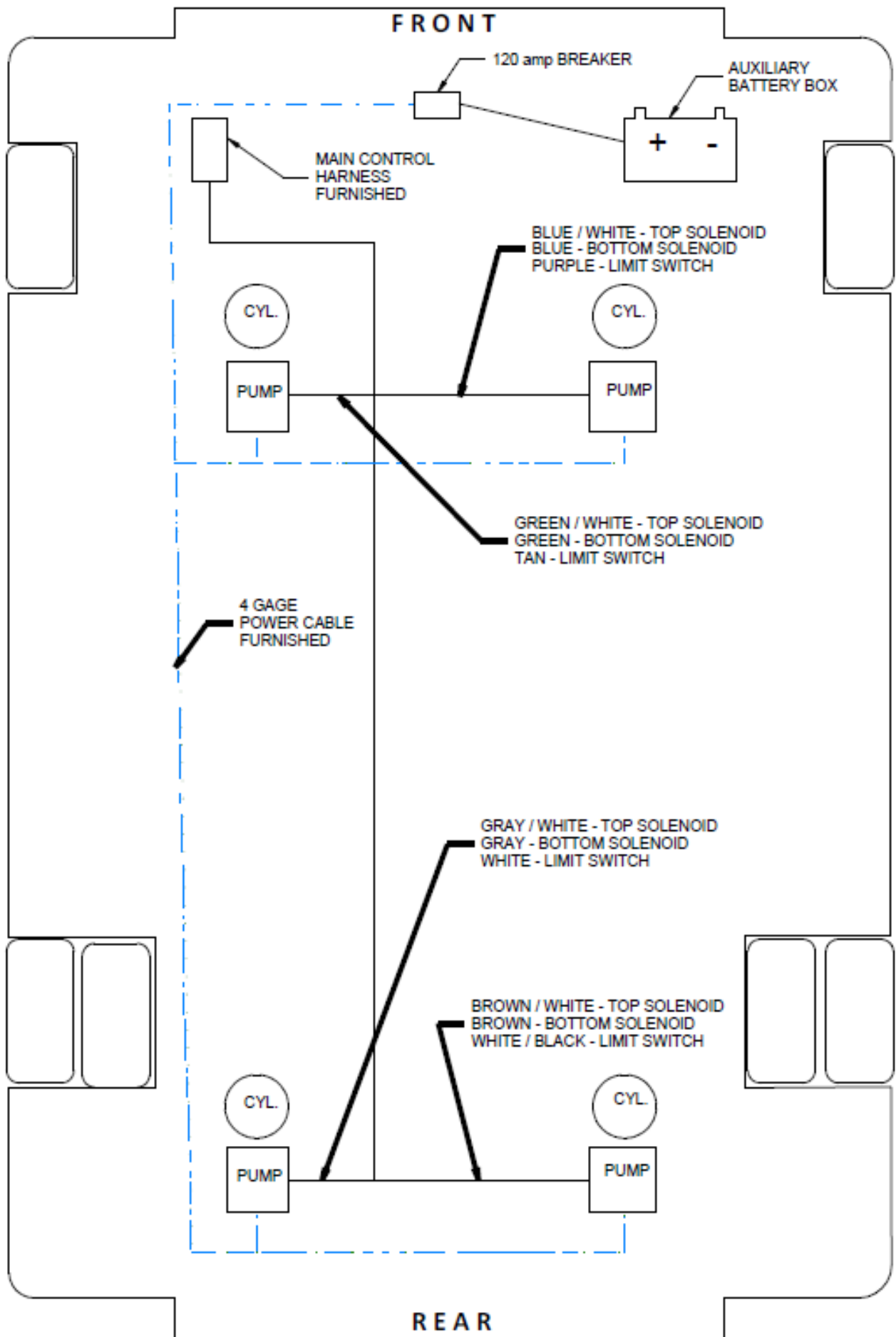

HOW TO PROGRAM “AUTO” SYSTEMS

- Turn panel/system on and let system run through its diagnostic mode. Lights will flash clockwise around the green foot.
- When the lights stop flashing, push the button labeled “FRONT” 5 times. Then press the button labeled “REAR” 5 times. Once you have done this all lights on panel will begin to flash. This means you have reached in the system what is called zero mode.
- At this time you can operate each corner or pair of levelers individually. For example:
 - Front indicator operates the right front.
 - Right operates the right rear.
 - Rear operates the left rear.
 - Left operates the left front.

IMPORTANT: IT IS RECOMMENDED TO LOWER 2 LEVELERS OR CORNERS AT A TIME. FOR EXAMPLE, LOWER LEFT FRONT AND RIGHT FRONT TOGETHER OR RIGHT FRONT AND RIGHT REAR. DOING SO WILL AVOID RAISING ONE PARTICULAR CORNER AT A TIME.

- Once you have the coach level, you can now STORE a new program into the system. To do so, push the retract button 3 times. If you wish to store the AIR DUMP MODE press the same button again 3 times.

NOTE: STORING THE AIR DUMP MODE IS ONLY NECESSARY ON UNITS THAT ARE AIR RIDE EQUIPPED. IF YOU ARE NOT STORING THIS FEATURE, SIMPLY WAIT TO ALLOW THE AIR DUMP LIGHT TO STOP FLASHING.

- If you do not want to store a new program, simply use the MANUAL RETRACT feature to avoid changing the original program.

AUTO/MANUAL PANEL OPERATION

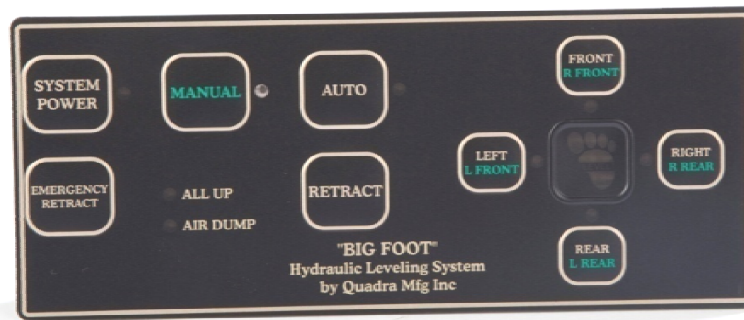

FIVE EASY STEPS:

1. Turn panel/system on and let system run through its diagnostic mode. Lights will flash clockwise around the green foot.
2. When the lights stop flashing, it's time to choose your function (MANUAL or AUTOMATIC). If choosing MANUAL, push button and hold until light comes on. For AUTOMATIC, push once and release.
3. When in the MANUAL mode, each leveler may be operated individually. FRONT operates right front. RIGHT operates right rear. REAR operates left rear. LEFT operates left front. When using this feature it is important to level the coach by using two levelers at a time or together. For example, right front and right rear.
4. When using the AUTOMATIC feature, simply push the AUTO button and then let the system operate itself. It is important at this time that there is NO MOVEMENT IN THE COACH.
5. Retracting levelers: When in the MANUAL mode, push the RETRACT button and hold until desired levelers are retracted. When in the AUTO mode, simply push the RETRACT button one time.

MECHANICAL / HYDRAULIC TROUBLE SHOOTING

Possible Cause	Low fluid level.	Air in hydraulic system: bleed system.	Loose or broken hydraulic line or fittings, tank	Hydraulic lines and control wires reversed : extend to	Spray rams with dry type silicone spray.	Leveler may be in a bind due to full extension, relieve pressure by placing wood block under opposite leveler
Problem						
Pump runs, but leveler won't retract or extend.	X					X
One or more levelers are fully extended and will not retract.	X	X				X
Levelers creep down while driving or parked.	X	X				
Levelers creep up when leveled.		X				
Fluid on footpad or ground around leveler.			X			
Leveler touches down, but will not lift coach.		X		X		
Leveler makes screeching or groaning sound while extending and retracting.					X	

MECHANICAL / HYDRAULIC TROUBLE SHOOTING

Possible Cause	No "All Up" light. Visually check levelers are completely retracted before moving.										
	Air dump not programmed into sensor. See Panel programming section.										
	Push and hold manual button for 5 seconds.										
	Zero mode, sensor needs programming see panel programming section.										
	Sensor timed out, parking spot more than 5° out of level										
	Sensor timed out. Make sure no one is moving about while levelling.										
	Check vehicle fuse panel & check for loose under dash wiring.	X									
	Loose footpad or bad limit switch.										
	System battery cable connected to negative battery terminal.		X								
	Ignition switch on or acc.				X						
House battery low.	X	X									
Circuit breaker tripped. Breaker will be close to battery.	X										
Panel won't turn on.		X									
Panel is on, clicking sound under coach.	X	X		X							
No "All Up" light.					X						
Panel on, no diagnostic cycle (auto				X							
Panel on, front and rear lights flashing.		X									
Panel on, left and right light flashing.						X	X				
Panel on, all lights flashing.								X			
Panel wont go into manual mode (auto panel									X		
No air dump (Air ride coaches and tour buses with auto panel).									X		
Panel buzzer goes off with engine running.										X	

MEDIUM TANK ASSEMBLY

#M26850

OVERALL DIMENSIONS:
9" WIDE
12.5" TALL
5.75" DEEP

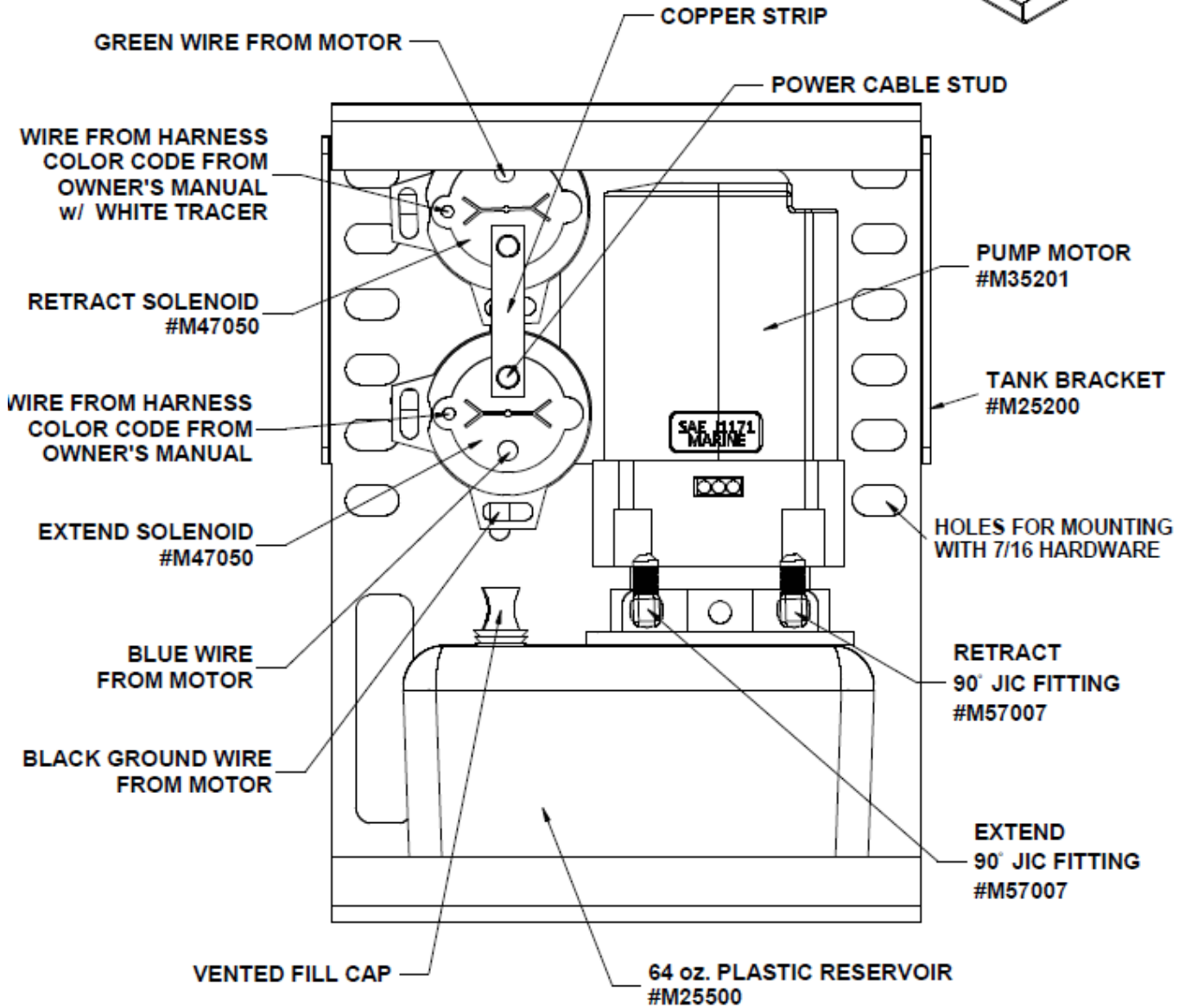
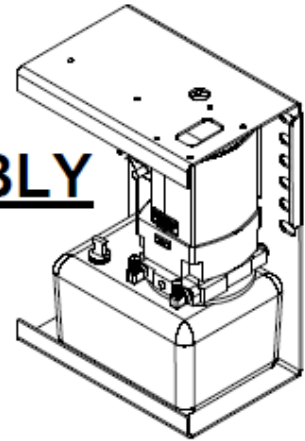

4 PT WIRING HARNESS COLOR CODE DIAGRAM:
LEFT FRONT: GREEN/WHITE & GREEN
RIGHT FRONT: BLUE/WHITE & BLUE
LEFT REAR: GREY/WHITE & GREY
RIGHT REAR: BROWN/WHITE & BROWN

NOT PICTURED:
TANK COVER
(BLACK TEXTURED PLASTIC)
#M12002

CYLINDER ASSEMBLY

Cylinder sizes & mounting locations & weld-on mounting brackets vary from application to application. Feel free to call Quadra Mfg. for more information on your system.

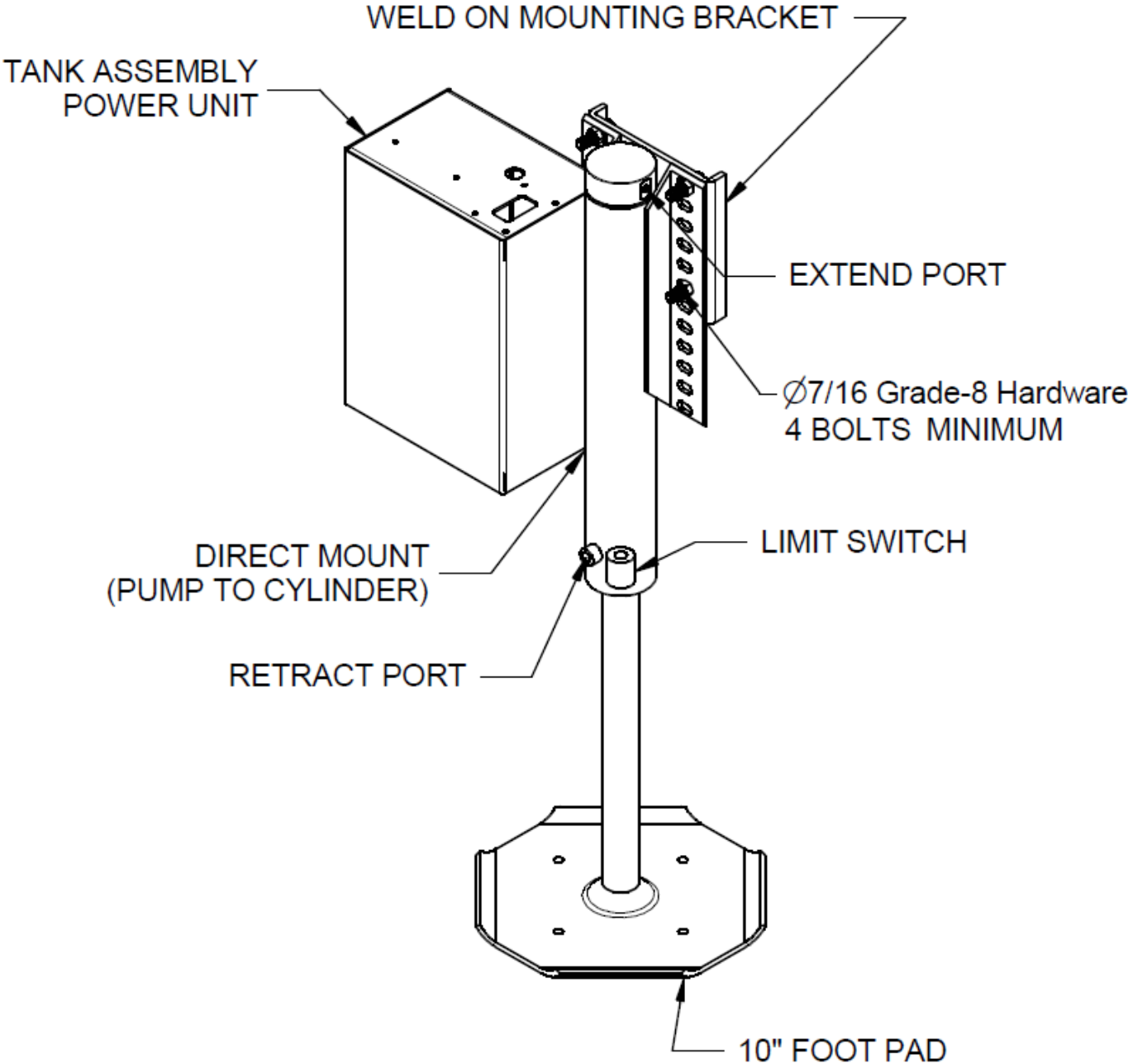



I.D.S. Sensor



Sensor Mounting Bracket



Bezel Mounting Ring



Foam Bezel



Auto Control



Manual Control



6 Pin Harness



Interface Harness



Limit Switch & Pin Extension



120 amp Breaker

CONTROL PANEL INSTALLATION

NOTE: CONTROL PANELS ARE DESIGNED TO BE MOUNTED IN OR AROUND THE DASH. THEY ARE NOT DESIGNED FOR FLOOR MOUNT OR OUTSIDE OF THE VEHICLE.

CUT OUT DIAGRAM: CUT ALONG THE SOLID LINE OF BEZEL RING DIAGRAM BELOW.

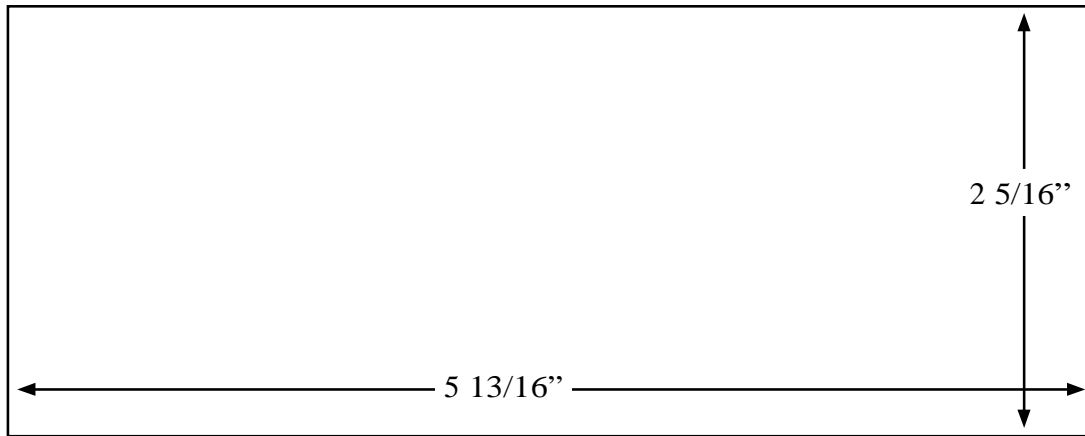

BEZEL RING

Warranty Guide

1 Year Full Labor Warranty
2 Year Full Parts Warranty
Lifetime Warranty on cylinders

Quadra Manufacturing warrants against manufacture's defect due to workmanship and/or material. For more warranty information please contact us at 269-483-9633.

Owner must activate warranty!

This warranty only applies to the original owner and the first owner must call to activate warranty within 30 days from the date of purchase.

To activate warranty call

269-483-9633

Monday-Friday 8-5 Eastern

Emergency Service

For after hours emergency service please call our normal office number and listen for the prompt to enter in your phone number, this sends a page to a service tech that will get back to you shortly.

269-483-9633

